



OMEC NORTH AMERICA INC

CAST IRON - GENERAL PURPOSE MOTORS

PRODUCT FEATURES

Model Number	OMT3-90S00-4 1.1KW		
Standard	IEC 60034-1	Output	1.10 KW
Hazardous Classification	None (Safe Area)	No of Poles	4 Pole
Efficiency Class	IE3	Frame Size	90S
Number of Phases	3 Phase- Induction	Mounting Type	B3; B35, B14, B5, V1
Material of Construction	Cast Iron	Enclosure Type / Cooling	TEFC-IC411
Insulation Class	Class F	Degree of Protection	IP55
Temperature Rise Class	80K (B class)	Duty Cycle	S1- Continuous Duty
Ambient Temperature	-15°C ~ 50°C	Service Factor	SF 1.15
Starting Method	DOL / WYE-DELTA	Operating Altitude	1000 masl

TECHNICAL DETAILS

Winding Connection	Y (Star)						
Frequency	50Hz			60Hz			
Rated Speed	1430 Rpm			1715 Rpm			
Voltage	380	400	415	380	400	440	460
Full Load Current [IN]	2.65 A	2.52 A	2.43 A	2.65 A	2.52 A	2.29 A	2.19 A
Locked Rotor Current [IL / IN]	6.8	6.8	6.8	6.8	6.8	6.8	6.8
Full Load Torque [TN]	7.35 Nm	7.35 Nm	7.35 Nm	6.13 Nm	6.13 Nm	6.13 Nm	6.13 Nm
Locked Rotor Torque [TL / TN]	2.3	2.3	2.3	2.8	2.8	2.8	2.8
Breakdown Torque [TB / TN]	2.3	2.3	2.3	2.8	2.8	2.8	2.8
Efficiency	50% load	81.5%	81.5%	81.5%	81.5%	81.5%	81.5%
	75% load	83.9%	83.9%	83.9%	83.9%	83.9%	83.9%
	100% load	84.1%	84.1%	84.1%	84.1%	84.1%	84.1%
Power Factor (cos φ)	50% load	0.53	0.53	0.53	0.53	0.53	0.53
	75% load	0.69	0.69	0.69	0.69	0.69	0.69
	100% load	0.75	0.75	0.75	0.75	0.75	0.75

OTHER DETAILS

Bearing Configuration (DE / NDE)	Ball Bearing / Ball Bearing		
Bearing Lubrication Type	Grease - ESSO UNIREX N2		
Bearing Series Type	DE:	6205-2Z/C3	NDE: 6205-2Z/C3
Vibration	1.6 mm/sec	Direction of Rotation	CW or CCW
Moment of inertia (kg.m ²)	0.0040	Sound Pressure Level	66 dB(A)
Final Colour	RAL-5012 : BLUE	Paint Specification	2 Pack Epoxy
Terminal Box Position	TOP/SIDE	Weight	25 kg

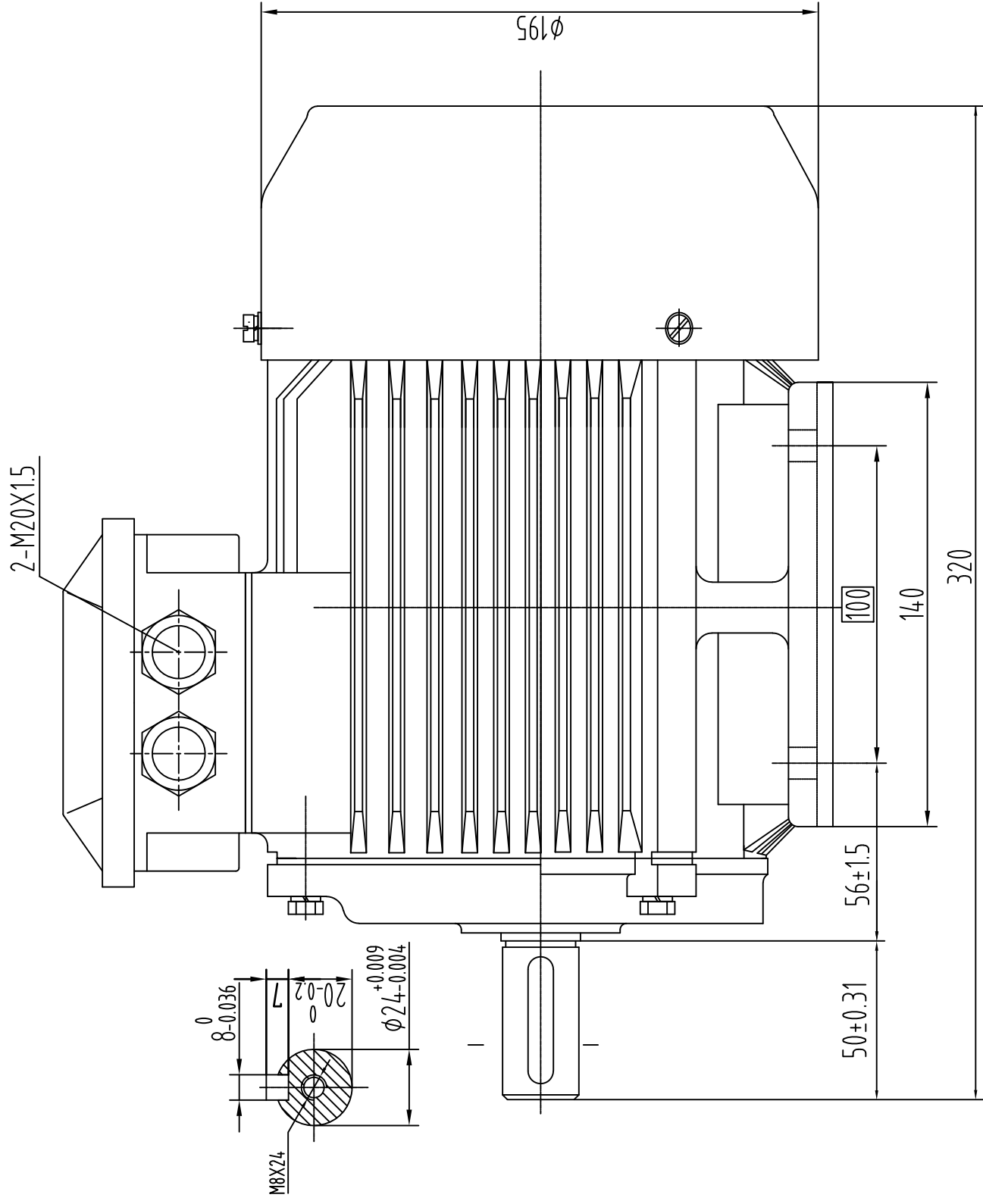
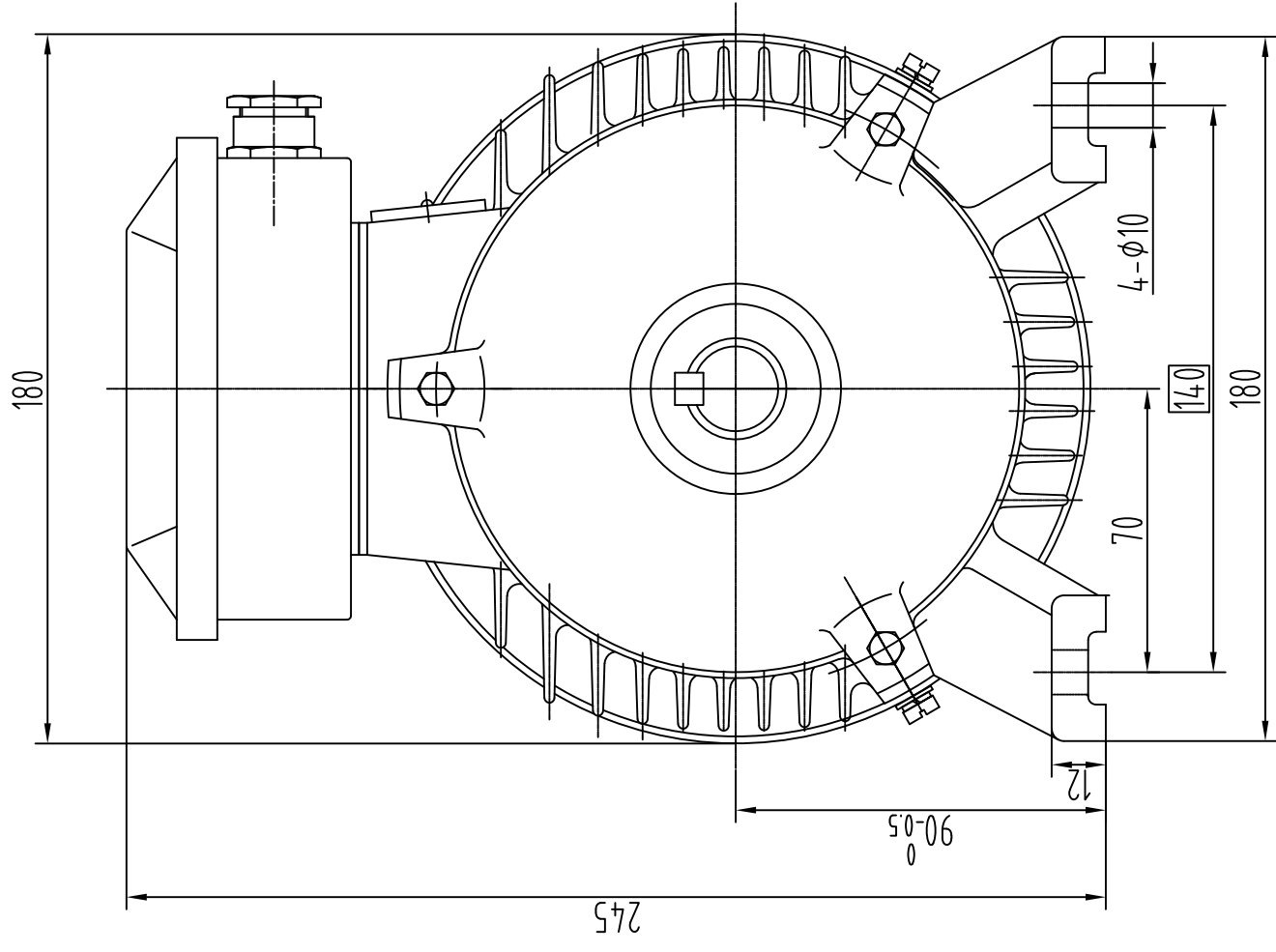

Drawing Title: OMT3 Type-1

Motor Frame: 90S



Outline Drawing	Sheet No.	Dim. Size	Scale
	1 OF 1	mm A3	1:5

IP55-Cast Iron B3 MOTORS

OMEC NORTH AMERICA INC.

A.J.B.	15.Jan.2025	00
Drawn By	Date	Approved By
		Rev.

This document is the sole property of OMEC and all information contained herein may neither be reproduced, used, disclosed, transmitted nor in any way made public without permission of the OWNER.



OMEC NORTH AMERICA INC.

Performance Curves

kW: 1.1 RPM: 1430

IE3 GENERAL PURPOSE MOTORS- OMT 400V 50Hz

