



# OMEC NORTH AMERICA INC

CAST IRON - GENERAL PURPOSE MOTORS

## PRODUCT FEATURES

Model Number	OMT3-132S00-2 7.5KW		
Standard	IEC 60034-1	Output	7.50 KW
Hazardous Classification	None (Safe Area)	No of Poles	2 Pole
Efficiency Class	IE3	Frame Size	132S
Number of Phases	3 Phase- Induction	Mounting Type	B3; B35, B14, B5, V1
Material of Construction	Cast Iron	Enclosure Type / Cooling	TEFC-IC411
Insulation Class	Class F	Degree of Protection	IP55
Temperature Rise Class	80K (B class)	Duty Cycle	S1- Continuous Duty
Ambient Temperature	-15°C ~ 50°C	Service Factor	SF 1.15
Starting Method	DOL / WYE-DELTA	Operating Altitude	1000 masl

## TECHNICAL DETAILS

Winding Connection	Δ (Delta)						
Frequency	50Hz			60Hz			
Rated Speed	2930 Rpm			3515 Rpm			
Voltage	380	400	415	380	400	440	460
Full Load Current [ IN ]	14.21 A	13.50 A	13.01 A	14.21 A	13.50 A	12.27 A	11.74 A
Locked Rotor Current [ IL / IN ]	7.9	7.9	7.9	7.9	7.9	7.9	7.9
Full Load Torque [ TN ]	24.45 Nm	24.45 Nm	24.45 Nm	20.38 Nm	20.38 Nm	20.38 Nm	20.38 Nm
Locked Rotor Torque [ TL / TN ]	2.0	2.0	2.0	2.4	2.4	2.4	2.4
Breakdown Torque [ TB / TN ]	2.3	2.3	2.3	2.8	2.8	2.8	2.8
Efficiency	50% load	88.2%	88.2%	88.2%	88.2%	88.2%	88.2%
	75% load	90.0%	90.0%	90.0%	90.0%	90.0%	90.0%
	100% load	90.1%	90.1%	90.1%	90.1%	90.1%	90.1%
Power Factor (cos φ)	50% load	0.71	0.71	0.71	0.71	0.71	0.71
	75% load	0.83	0.83	0.83	0.83	0.83	0.83
	100% load	0.89	0.89	0.89	0.89	0.89	0.89

## OTHER DETAILS

Bearing Configuration (DE / NDE)	Ball Bearing / Ball Bearing		
Bearing Lubrication Type	Grease - Mobil Polyrex EM		
Bearing Series Type	DE:	6208-2Z/C3	NDE: 6208-2Z/C3
Vibration	1.6 mm/sec	Direction of Rotation	CW or CCW
Moment of inertia (kg.m <sup>2</sup> )	0.0195	Sound Pressure Level	85 dB(A)
Final Colour	RAL-5012 : BLUE	Paint Specification	2 Pack Epoxy
Terminal Box Position	TOP/SIDE	Weight	70 kg

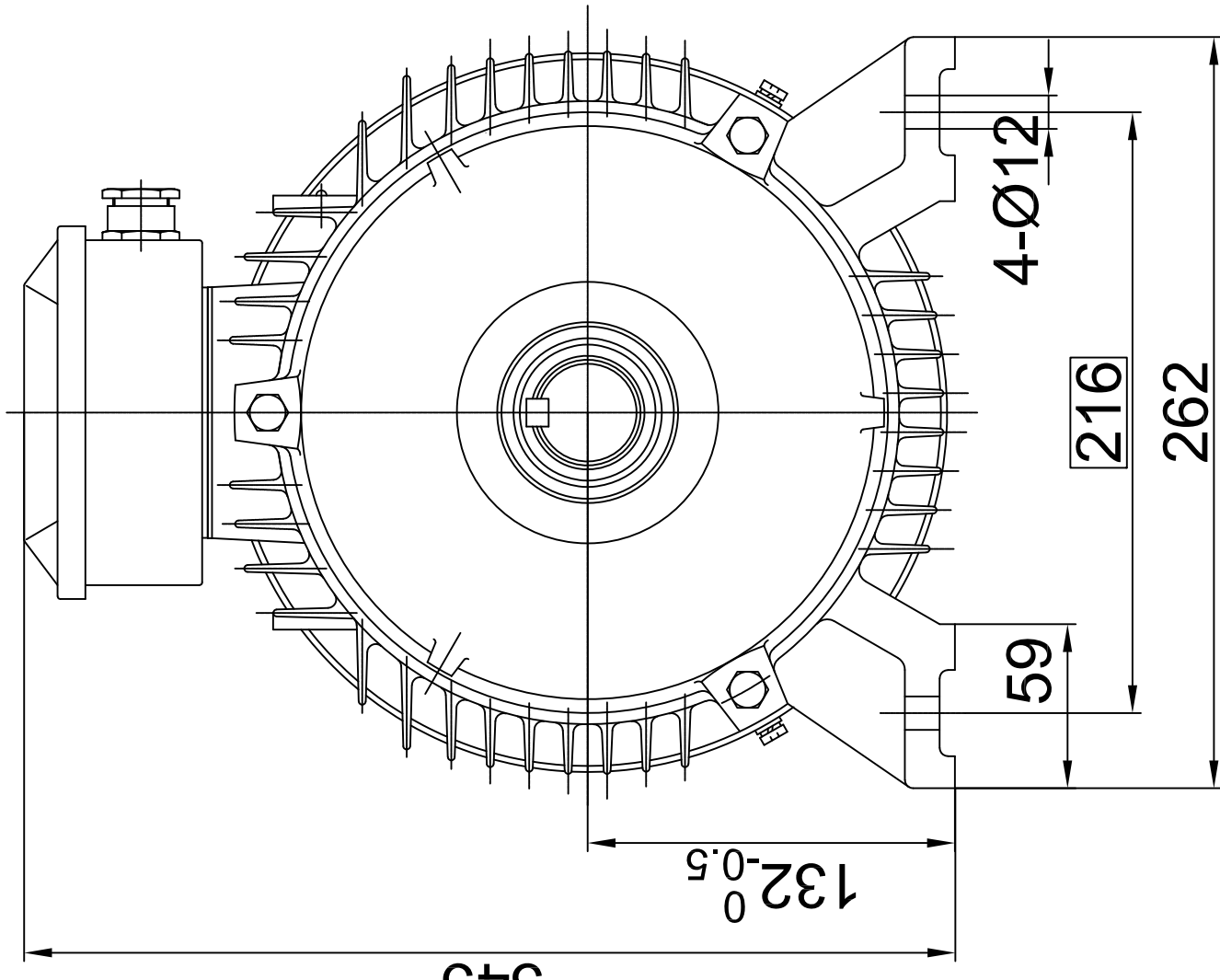
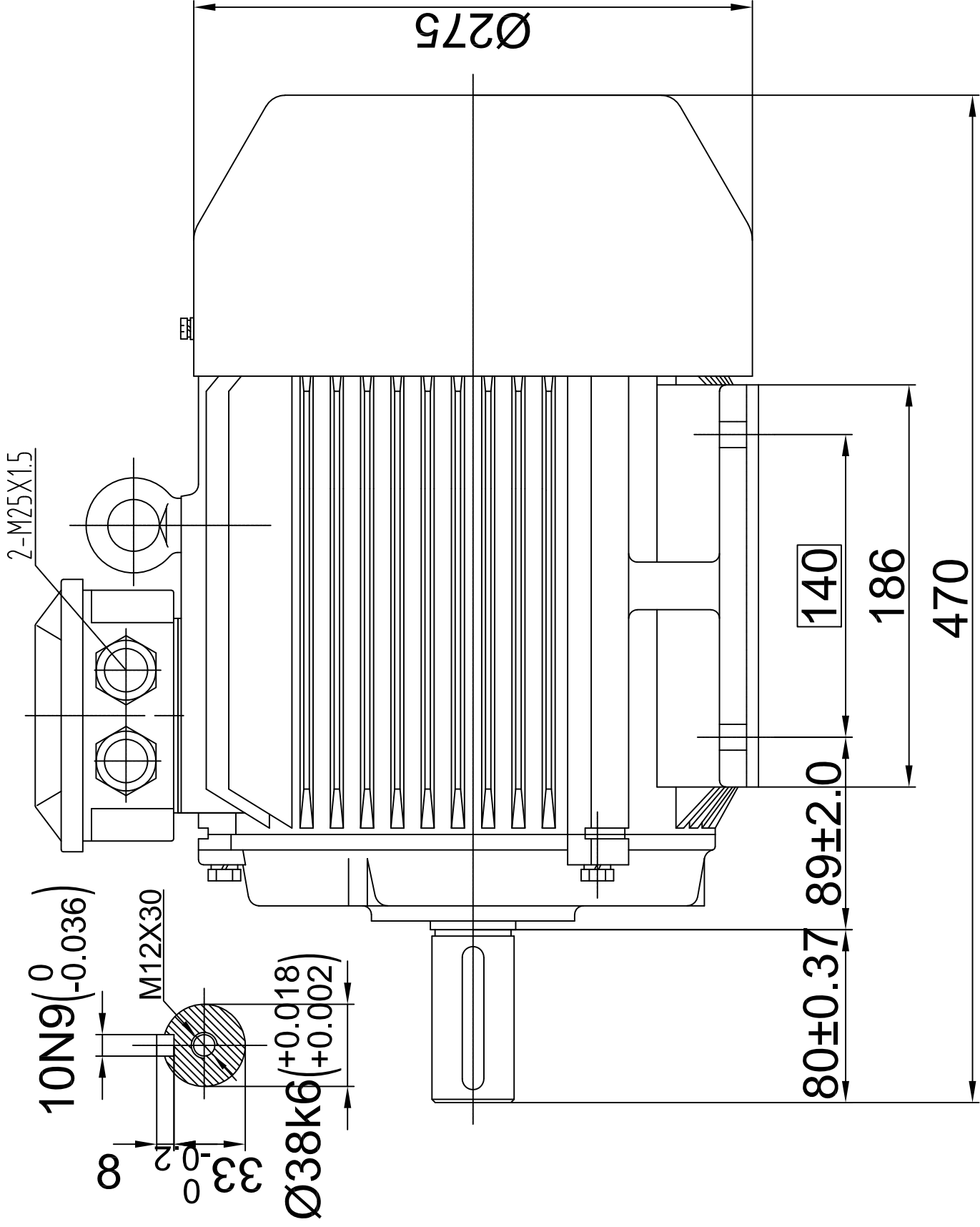

**IP55-Cast Iron B3 MOTORS**

**OMEC NORTH AMERICA INC.**

Drawing Title:		Description: OMT3 Type-1	
Outline Drawing		Motor Frame: 132S	
Sheet No.	Dim. Size	Scale	
1 OF 1	mm A3	1:5	



A.J.B.	15.Jan.2025	00
Drawn By	Date	Approved By
		Rev.



# OMEC NORTH AMERICA INC.

## Performance Curves

kW: 7.5 RPM: 2930

IE3 GENERAL PURPOSE MOTORS- OMT 400V 50Hz

